

SECAM PROCESSOR CIRCUIT

GENERAL DESCRIPTION

The TDA3590A processor circuit converts SECAM signals into sequential phase-modulated (quasi-PAL) signals. It combines all the functions of the TDA3590, TDA3591 and TDA3591A to provide a complete SECAM processor system. The circuit is intended for use in conjunction with TDA3560, TDA3561, TDA3561A, TDA3562A or TDA3566 to provide SECAM/PAL/NTSC/black-and-white processor combinations.

Features

- Limiter/amplifier for chrominance signal
- SECAM demodulator
- Clamp circuits and de-emphasis for colour difference signals
- Modulator to convert colour difference signals into sequential, phase-modulated signals
- Identification circuit for horizontal, vertical or combined horizontal and vertical SECAM identification
- Divider circuit to provide 4,4 MHz carrier from 8,8 MHz signals generated in TDA3560/61/61A/62A/66
- Sandcastle pulse detector
- SECAM switch and PAL matrix
- Video amplifier
- Pin compatibility with TDA3590, TDA3591 and TDA3591A when application requires SECAM ident priority (does not apply with PAL ident priority)

QUICK REFERENCE DATA

Supply voltage	$V_P = V_{17-2}$	typ.	12 V
Supply current	$I_P = I_{17}$	typ.	100 mA
Chrominance amplifier and demodulator			
Input signal PAL (peak-to-peak value)	$V_{4-2(p-p)}$	typ.	550 mV
Input signal SECAM (peak-to-peak value)	$V_{4-2(p-p)}$	typ.	100 mV
Output signal PAL (peak-to-peak value) at $V_{16(p-p)} = 1,2$ V	$V_{8-2(p-p)}$	typ.	900 mV
Output signal SECAM (peak-to-peak value)	$V_{8-2(p-p)}$	typ.	500 mV
Identification			
Input voltage range for horizontal identification (pin 5)	V_{5-2}		0 to 8 V
Input voltage range for vertical identification (pin 5)	V_{5-2}		10,5 to 12,0 V
Voltage at pin 6 for PAL	V_{6-2}	typ.	10,2 V
Voltage at pin 6 for SECAM	V_{6-2}	typ.	7,0 V
Sandcastle pulse detector			
Vertical blanking level	V_{19-2}	typ.	1,5 V
Horizontal blanking level	V_{19-2}	typ.	3,5 V
Burst gating level	V_{19-2}	typ.	7,2 V
Luminance amplifier			
Luminance input signal (peak-to-peak value)	$V_{16-2(p-p)}$	typ.	1,2 V
Luminance output signal (peak-to-peak value)	$V_{15-2(p-p)}$	typ.	3,0 V
PAL matrix and SECAM switch			
Burst signal amplitude (peak-to-peak value)	$V_{11}; 12-2(p-p)$	typ.	60 mV
Amplification for PAL		typ.	0,5 dB
Amplification for SECAM		typ.	6 dB

PACKAGE OUTLINE

24-lead DIL; plastic (with internal heat spreader) (SOT101B).

PINNING

1. Identification coupling input for PAL/not-PAL identification using half the saturation voltage of the PAL decoder.
2. Ground.
3. Limiter feedback.
4. SECAM video input.
5. Identification selection input using a d.c. level to preset the identification mode of horizontal/vertical detection + black level clamping/insertion.
6. Storage circuit input to SECAM/not-SECAM identification detector.
7. Divider circuit input of 8,8 MHz from the PAL decoder.
8. Chrominance signal output comprising PAL or processed SECAM (quasi-PAL).
9. Carrier signal phase identification input from the burst phase detector of the PAL decoder.
10. As for pin 9.
11. Direct chrominance input to SECAM switch/PAL matrix.
12. Delayed chrominance input to SECAM switch/PAL matrix.
13. Colour difference output (R-Y).
14. Colour difference output (B-Y).
15. Luminance output.
16. Luminance/PAL input.
17. Positive supply voltage (V_p).
18. Decoupled positive supply voltage.
19. Three-level sandcastle pulse input.
20. De-emphasis circuit connection.
21. Storage capacitor connection for (B-Y) clamp.
22. Storage capacitor connection for (R-Y) clamp.
23. Connection for reference tuned circuit for SECAM chrominance and identification demodulators.
24. As for pin 23.

FUNCTIONAL DESCRIPTION

Demodulation

The chrominance and identification demodulators of the TDA3590A both share the same reference tuned circuit (pins 23 and 24). The identification circuit automatically detects whether the incoming signal is SECAM or not-SECAM.

When the incoming signals are not-SECAM (PAL/NTSC/black-and-white) they are diverted via pin 16 to the chrominance output at pin 8 and no signal demodulation takes place. The delay line connected to pin 16 delays the signals to equalize the delay of the SECAM processor circuitry. When SECAM signals are received the PAL signal path is switched off.

Incoming SECAM signals are applied to pin 4 via an external bell filter. The signals are amplified, limited and then demodulated. The limiters give optimum i.f. interference suppression. Only one demodulator is necessary as the colour difference signals are available sequentially. After demodulation the colour difference signals are separated by an H/2 switch and then applied to (R-Y) and (B-Y) clamp circuits where the black levels are clamped to the same d.c. level. The optimum black level can be obtained at the end of the horizontal burst, so the timing of the (R-Y) and (B-Y) clamp is determined by the last 1,45 μ s of the burst gate pulse.

The two colour difference signals are combined again after clamping and then applied to the modulator via de-emphasis, blanking and reinsertion circuits.

The ratio of (R-Y) to (B-Y) at the de-emphasis output (pin 20) is 1,78. The external de-emphasis components of $R = 1 \text{ k}\Omega$ and $C = 470 \text{ pF}$ give a spread at the internal de-emphasis network $< 20\%$.

FUNCTIONAL DESCRIPTION (continued)

If artificial black level reinsertion is required the burst gating pulse (Fig. 2) is used to time black level clamping. Artificial black levels are inserted during the horizontal blanking period when $V_{5-2} > 2$ V. The clamp circuits then react to the artificial levels instead of the demodulated burst signals (this is necessary when no horizontal burst signals are available). The inserted signals may not be identical to the demodulated signals because of circuitry spread but this can be corrected by detuning the demodulator reference tuned circuit.

Modulation

A burst signal is reinserted into the combined SECAM signal at the input to the sequential phase modulator. The nominal duration of this burst is $2,85 \mu\text{s}$ which approximates to the duration of the PAL burst and, in combination with the horizontal blanking pulse (used as keying pulse in the SECAM switch), minimizes interference in the a.c.c. loop of the TDA3560/61/62.

At the input to the modulator the (R-Y) and (B-Y) signals have a positive phase position for magenta colour. The modulation carriers for the (R-Y) and (B-Y) signals are 90° out of phase; the burst is modulated in the + (R-Y) direction and is only present during an (R-Y) line, the modulated (R-Y) component has the same phase position as the (R-Y) burst for magenta colour.

The chrominance output from pin 8, in the SECAM mode, is a quasi-PAL signal with alternate line, sequential modulation. Odd and even harmonics of the 4,4 MHz carrier introduced by the modulator are suppressed by internal filters. A correction is made to the burst-chrominance ratio of the quasi-PAL signals for equal saturation of PAL and SECAM signals.

Identification

Identification of the SECAM signal is performed using the fact that only SECAM has a line-to-line difference in demodulated voltage level. This is detected during the last $1,5 \mu\text{s}$ of the burst gate pulse. A flip-flop, which is switched by the leading edge of the sandcastle time blanking pulse, provides the reference input to the identification detector. Here the phase of the flip-flop is compared with that of the changing voltage levels from the demodulator. The SECAM identification circuits operate when selected by the voltage on pin 5; this may be horizontal, vertical or combined horizontal and vertical identification, depending on the switching arrangements of pin 5. An internal voltage divider presets pin 5 to 6 V to give automatic selection of horizontal identification plus black level re-insertion. Vertical identification is selected by taking the voltage on pin 5 above 10,5 V, then the system compares the demodulator output voltage only during line scanning of the vertical blanking.

Information obtained from the identification detector is also used for colour killing and, if required, for switching to PAL.

Luminance amplification

The luminance amplifier input at pin 16 can be up to 1,2 V (peak-to-peak value) which equates to a peak-to-peak voltage of 2,7 V -7 dB. The amplifier gain is typically 8 dB. The luminance clamping circuit is activated during the SECAM identification timing (see Fig. 2).

Sandcastle pulse detection

The sandcastle pulse detector requires a three-level sandcastle pulse to provide horizontal blanking, vertical blanking and burst gate pulses. The detected burst gate pulse triggers a pulse generator which produces two timing pulses, pulse 'A' and pulse 'B' (see Fig. 2). Pulse 'A' is used to time the PAL burst modulator. Pulse 'B' provides the timing of the (R-Y) clamp (present only during a red line); the (B-Y) clamp (present only during a blue line); the luminance clamp (present every line); and the SECAM horizontal identification circuit.

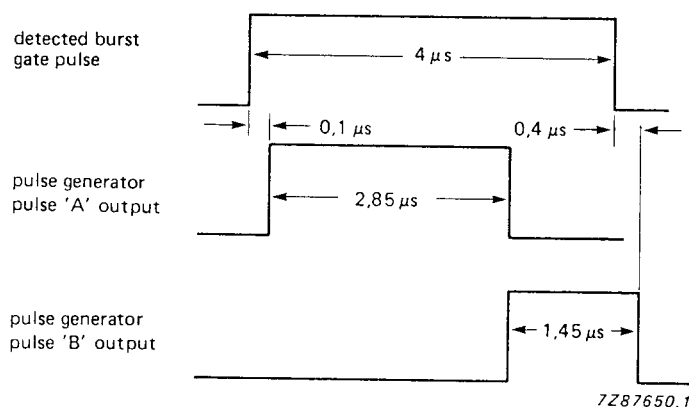

Fig. 2 Burst gate timing pulse generation.

PAL matrix and SECAM switch

The PAL matrix and SECAM switch is included in the TDA3590A to facilitate handling of the two chrominance signal types, PAL and SECAM. For PAL, the direct chrominance signal and the chrominance signal delayed by the PAL delay line are used by the PAL matrix to separate the two colour difference signals. Phase accuracy is not critical for this operation as the colour difference signals are not mixed. For SECAM, the quasi-PAL sequential colour difference signals are separated by switching. The gain of the switching circuit is two times that for normal PAL reception to maintain signal balance between the two systems. The (B-Y) output from the SECAM switch is a signal with no burst; the (R-Y) output has a burst modulated in the + (R-Y) direction during the + (R-Y) line. There is minimal crosstalk between the colour difference signals in the SECAM switch.

Carrier generation

The carrier for the sequential phase modulator is obtained using the 8,8 MHz input from the PAL decoder. This input is divided by two to provide two 4,4 MHz signals with a phase relationship of 90° . Correct phasing between the 4,4 MHz and the PAL decoder is ensured by the 4,4 MHz phase identifier circuit which resets the divider if the phasing is wrong (see Figs 3 and 4 for inter-connections). The inputs/outputs to the phase identifier have internal current sources in the case of SECAM.

Coupling of identification systems

Coupling of system identification between TDA3590A and a PAL decoder is performed using the functions of pins 1 and 6. The voltage level at pin 1 is controlled by the PAL/not-PAL detection of the PAL decoder; the voltage level at pin 6 is a function of SECAM/not-SECAM detection of the TDA3590A modified by the action of pin 6 external circuit.

The circuit action is as follows and is summarized in Table 1.

Channel switching	During channel switching pin 6 is taken rapidly to a high voltage ($\pm 10,2 \text{ V}$) by the external circuit. This corresponds to the not-SECAM mode of the TDA3590A.
PAL	The high voltage level at pin 6 caused by channel switching is maintained by the TDA3590A when it recognizes the signal as not-SECAM. An internal current source keeps pin 6 voltage high, locking the TDA3590A in the not-SECAM mode. This condition is maintained even if reflected PAL signals are present. The PAL decoder recognizes the signal as PAL and takes pin 1 of TDA3590A to a voltage of between 0,5 and 2,6 V, depending on the setting of the saturation voltage. The system is thus locked in the PAL mode.

FUNCTIONAL DESCRIPTION (continued)

SECAM	The initial high voltage level ($\pm 10,2$ V) at pin 6 caused by channel switching sets the TDA3590A in the not-SECAM mode and during this time the PAL decoder detects a not-PAL signal. This causes a voltage at pin 1 of $< 0,4$ V which prevents the internal current source of TDA3590A maintaining the high voltage level of pin 6 which, in turn, allows the TDA3590A to detect SECAM. The initiation of SECAM detection is delayed by the action of pin 6 external circuit and commences when pin 6 approaches 9,1 V. The SECAM signals are converted by TDA3590A to quasi-PAL signals at pin 8 which are detected by the PAL decoder as PAL signals. The resulting modes of operation are SECAM for the TDA3590A and PAL for the PAL decoder, together giving a system operation in the SECAM mode.
Black-and-white	The TDA3590A is initially set in the not-SECAM mode as previously described. The PAL decoder detects not-PAL and the TDA3590A detects not-SECAM which results in a system operation in the colour-killing mode.

Table 1 System operating modes

TDA3590A mode	PAL decoder mode	system operating mode
SECAM	PAL	SECAM
SECAM	not-PAL	condition not used
not-SECAM	PAL	PAL
not-SECAM	not-PAL	black-and-white

RATINGS

Limiting values in accordance with the Absolute Maximum System (IEC 134)

Supply voltage (pin 17)	$V_P = V_{17-2}$	max.	13,2 V
Total power dissipation	P_{tot}	max.	1,88 W
Operating ambient temperature range	T_{amb}		-25 to + 65 °C
Storage temperature range	T_{stg}		-25 to + 150 °C

CHARACTERISTICS

$V_P = V_{17-2} = 12 \text{ V}$; $T_{\text{amb}} = 25 \text{ }^\circ\text{C}$; unless otherwise specified. The parameter values are valid only when the reference tuned circuit has been aligned as detailed in note 1.

parameter	symbol	min.	typ.	max.	unit
Supplies					
Supply voltage range (pin 17)	V_{17-2}	10,8	12,0	13,2	V
Supply current (pin 17)	I_{17}	—	100	—	mA
Input current (pin 18)	I_{18}	—	—	170	μA
Total power dissipation	P_{tot}	—	1,2	—	W
Chrominance amplifier and demodulator					
Input signal PAL (peak-to-peak value)	$V_{4-2(p-p)}$	—	—	1,1	V
Input signal SECAM (peak-to-peak value)	$V_{4-2(p-p)}$	15	100	300	mV
Input resistance (pin 4)	R_{4-2}	—	10	—	$\text{k}\Omega$
Input capacitance (pin 4)	C_{4-2}	—	—	5	pF
(R-Y)/(B-Y) ratio before modulation (pin 20)		—	1,78	—	
Relative black level deviation of colour difference signals before modulation (note 2)					
Output signal PAL (peak-to-peak value) at $V_{16(p-p)} = 1,2 \text{ V}$	$V_{8-2(p-p)}$	—	900	—	mV
Output signal SECAM (peak-to-peak value)	$V_{8-2(p-p)}$	—	500	—	mV
Output impedance	$ Z_{8-2} $	—	50	—	Ω
Input voltage for clamping on back porch of colour difference signals	V_{5-2}	—	—	0,5	V
Input voltage for artificial black level insertion after demodulation	V_{5-2}	2	—	—	V
Input resistance between pins 23 and 24	R_{23-24}	—	4	—	$\text{k}\Omega$
Input capacitance between pins 23 and 24	C_{23-24}	—	15	—	pF
Linearity of (B-Y) signal (pin 8) (note 3)		85	92	—	%
Linearity of (R-Y) signal (pin 8) (note 4)		93	100	—	%
Input resistance (pin 5)	R_{5-2}	—	10	—	$\text{k}\Omega$
Chrominance demodulator zero point stability (pin 20) (note 5)	f_0	—	5	—	kHz
Offset (B-Y) black level (pin 8) at f_0 clamping; $f_{\text{offset}} = 4,4 \text{ MHz}$		—	-15	—	kHz
Offset (R-Y) black level (pin 8) at f_0 clamping; $f_{\text{offset}} = 4,4 \text{ MHz}$		—	-25	—	kHz

CHARACTERISTICS (continued)

parameter	symbol	min.	typ.	max.	unit
Identification SECAM/not-SECAM					
Input voltage range for horizontal identification (pin 5)	V ₅₋₂	0	—	8	V
Input voltage range for vertical identification (pin 5)	V ₅₋₂	10,5	—	V _p	V
Voltage at pin 6 for PAL	V ₆₋₂	—	10,2	—	V
Voltage at pin 6 for SECAM	V ₆₋₂	—	7,0	—	V
Identification ON for SECAM	V ₆₋₂	—	10,6	—	V
Colour OFF for SECAM	V ₆₋₂	—	9,7	—	V
Colour ON for SECAM	V ₆₋₂	—	9,0	—	V
Voltage at pins 9 and 10 for SECAM	V _{9-2; 10-12}	—	10,5	—	V
Voltage between pins 9 and 10 for SECAM	V ₉₋₁₀	—	—	3	mV
Permissible voltage range at pins 9 and 10 for PAL	V _{9-2; 10-2}	6,8	—	10,2	V
Sandcastle pulse detector and clamping pulse generator					
Voltage level at which the vertical blanking pulse is separated	V ₁₉₋₂	1,0	1,5	2,0	V
required pulse amplitude (peak-to-peak value)	V _{19-2(p-p)}	2,1	—	2,9	V
Voltage level at which the horizontal blanking pulse is separated	V ₁₉₋₂	3,0	3,5	4,0	V
required pulse amplitude (peak-to-peak value)	V _{19-2(p-p)}	4,1	—	6,6	V
Voltage level at which the burst gating pulse is separated	V ₁₉₋₂	6,7	7,2	7,7	V
required pulse amplitude (peak-to-peak value)	V _{19-2(p-p)}	7,8	—	V _p	V
Input current at V ₁₉₋₂ = 7 V	I ₁₉	—	—	40	μA
Carrier generator (note 6)					
Input signal from TDA3560/61/61A/62A/66 (peak-to-peak value)	V _{7-2(p-p)}	150	—	—	mV
Input resistance	R ₇₋₂	—	4	—	kΩ
Input capacitance	C ₇₋₂	—	5	—	pF

parameter	symbol	min.	typ.	max.	unit
Luminance amplifier					
Input signal (peak-to-peak value)	$V_{16-2(p-p)}$	—	1,2	1,7	V
Chrominance input signal when no luminance information is present (peak-to-peak value)	$V_{16-2(p-p)}$	—	—	1	V
Gain (pin 16 to 15) at $f_{16} = 4,4$ MHz	G_{16-15}	—	8	—	dB
Input current (pin 16)	I_{16}	—	—	1	μA
Input resistance during clamping (pin 16)	R_{16-2}	—	2,9	—	$k\Omega$
Output impedance (pin 15) at $I_{15} = 2$ mA	$ Z_{15-2} $	—	20	—	Ω
Frequency response at -3 dB (pin 16 to 15)	f	6	—	—	MHz
Gain (pin 16 to 8) at $f_{16} = 4,4$ MHz; not-SECAM condition	G_{16-8}	—	7	—	dB
Frequency response at -3 dB (pin 16 to 8) not-SECAM condition	f	—	5	—	MHz
PAL matrix and SECAM switch					
Burst signal amplitude (peak-to-peak value)	$V_{11; 12(p-p)}$	—	60	—	mV
Input resistance	$R_{11; 12-2}$	—	900	—	Ω
Input capacitance	$C_{11; 12-2}$	—	3	—	pF
Amplification for PAL	A	—	0,5	—	dB
Amplification for SECAM	A	—	6	—	dB
Difference in amplification from inputs to one output for PAL	ΔA	—	—	0,5	dB
Line-to-line phase error in (R-Y) output for zero error in (B-Y) output for PAL		—	—	3,5	deg
Output impedance	$ Z_{13; 14-2} $	—	50	—	Ω
Identification PAL/not-PAL					
Input condition for PAL (pin 1)	V_{1-2}	0,8	—	2,1	V
Input conditions for not-PAL (pin 1): lower voltage level	V_{1-2}	—	—	< 0,4	V
upper voltage level	V_{1-2}	> 2,6	—	V_p	V

Notes to the characteristics

1. The parameter values given in the characteristics are valid only when the following alignment procedure is performed:
 - a. Supply a SECAM signal input to pin 4 at 100 mV (peak-to-peak value) without deviation during a red and blue line (SECAM black colour information).
 - b. Align the reference tuned circuit so that the output signal from pin 8 to the PAL decoder is minimum during scan (PAL black colour information).
2. When an artificial black level is inserted after demodulation the resulting black level deviation depends on the adjustment of the demodulator tuned circuit. It is therefore possible to obtain a value of 0%.
3. (B-Y) linearity is defined by $V_{out(yellow)}/V_{out(blue)}$ where $f_{yellow} = (\text{typ.}) 4,02 \text{ MHz}$; $f_{blue} = (\text{typ.}) 4,48 \text{ MHz}$; $V_{S-2} = 2,0 \text{ V}$.
4. (R-Y) linearity is defined by $V_{out(cyan)}/V_{out(red)}$ where $f_{cyan} = (\text{typ.}) 4,68 \text{ MHz}$; $f_{red} = (\text{typ.}) 4,12 \text{ MHz}$; $V_{S-2} = 2,0 \text{ V}$.
5. When the input signal to the limiter (pin 4) changes from 300 to 15 mV (peak-to-peak value) the zero point of the chrominance demodulator shifts by a typical value of 5 kHz.
6. The phase delay between the oscillator output of TDA3560/61/61A/62A/66 and the input to TDA3590A pin 7 must be adjusted for minimum burst amplitude at pin 28 of the PAL decoder.

APPLICATION INFORMATION

The pin-to-pin functions of the application shown in Fig. 3 are described against the corresponding pin numbers.

Pin 4. Chrominance input

Typical input signal values (peak-to-peak) are: SECAM 100 mV; PAL 0,55 V. The input signal, which should be free from any sound modulation, is applied single-ended to pin 4 via a filter which has the bell-shaped bandpass required for SECAM signals.

Pin 5. Horizontal/vertical identification

Selection of horizontal or vertical identification depends on the external voltage applied to pin 5. When the d.c. level on pin 5 changes with time (pulse information) a combination of horizontal and vertical identification is possible.

Horizontal identification

When the voltage at pin 5 is $< 0,5 \text{ V}$ horizontal identification and black level clamping occur. The clamping is during the back porch of the colour difference signals. If artificial black level insertion is required the voltage at pin 5 should be between 2 and 8 V.

Vertical identification

When the voltage on pin 5 is $> 10,5 \text{ V}$ vertical identification occurs (identification on 9 lines in the vertical blanking period). In this mode the black level is artificially inserted after demodulation.

Pin 6. System identification

During PAL reception the typical voltage at pin 6 is 10,2 V. This causes the luminance stage to be connected internally to the chrominance output at pin 8 and also activates the PAL matrix for normal PAL signals. During SECAM reception the typical voltage at pin 6 is 7 V. This changes the internal connection of the output from the luminance stage to the sequential phase modulator and enables the SECAM switch. Noisy SECAM signals cause the voltage at pin 6 to increase, colour killing occurs at 9,8 V and colour is reinstated at 9,1 V.

Pin 7. Carrier generation

An 8,8 MHz signal from the PAL decoder is applied via pin 7 to the divider circuit in the TDA3590A. From this two 4,4 MHz signals are obtained with a phase shift of 90° with respect to each other. These signals are applied to the modulator via an H/2 switch. The delay of the 8,8 MHz input must be adjusted for minimum burst amplitude of the chrominance signal at pin 28 of the PAL decoder. With this condition the burst generated by the TDA3590A is in phase with the (R-Y) reference signal for the PAL decoder demodulator (the a.c.c. of the PAL decoder operates in the + (R-Y) direction).

Pin 8. Chrominance output

During PAL reception this output is connected internally to the luminance stage and a composite PAL video signal is present at pin 8. During SECAM reception the sequential phase modulator is connected to this output to give a quasi-PAL signal from pin 8. Typical peak-to-peak amplitudes of the signal from pin 8 are 900 mV for PAL (with peak-to-peak input at pin 16 of 1,2 V) and 500 mV for SECAM. The output signals are applied via a chrominance bandpass filter to the chrominance a.c.c. amplifier input of the PAL decoder.

Pins 9 and 10. Divider resetting

The output of the PAL decoder burst phase detector is connected to pins 9 and 10 of TDA3590A. During SECAM reception this signal carries differential a.c. current information about the phase relationship of the 4,4 MHz dividers of both ICs. The TDA3590A generates a minimum relative voltage between pins 9 and 10 at an absolute voltage level of 10,5 V. This overrules the PAL decoder oscillator control function causing the oscillator to run at $2 \times 4,43$ MHz.

Pins 11, 12, 13 and 14. SECAM switch and PAL matrix

The PAL matrix circuit is enabled by system identification of PAL reception. The signal inputs to the matrix are the (direct) a.c.c. composite video output from the PAL decoder via an attenuator to pin 11 and a delayed version of the same signal via a glass delay line to pin 12. Active matrixing takes place in the IC and the separated (R-Y) and (B-Y) signals are available at pins 13 and 14 respectively.

The SECAM switch circuit is selected by system identification of SECAM reception. The inputs to the SECAM switch are the sequentially modulated quasi-PAL signals, direct and delayed, to pins 11 and 12 respectively. The SECAM switch separates the (R-Y) and (B-Y) signals which are then available at pins 13 and 14 respectively.

Pins 15 and 16. Luminance signals

The maximum peak-to-peak amplitude of the input to pin 16 should be 1,7 V. The relatively high input impedance of the luminance amplifier allows a 22 nF coupling capacitor to be used. The luminance amplifier has internal input clamping and a gain of 8 dB. The output is available at pin 15.

During SECAM reception the luminance signal is delayed approximately 470 ns by an external delay line to equalize the SECAM processing delay. The luminance and chrominance outputs are then correctly timed.

During PAL reception the PAL composite video signal passes through the external delay line and, after amplification, is available at pins 15 and 8.

APPLICATION INFORMATION (continued)**Pins 17 and 18. Supply voltage (+ 12 V)**

Correct operation is ensured within the supply voltage range of 10,8 to 13,2 V. The typical power dissipation of the IC at 12 V is 1,2 W.

Pins 17 and 18 are separated by an external RC filter. Pin 18 supplies all the output stages and the biasing for several current sinks in the IC. Separation of the supply voltages minimizes crosstalk between the various parts of the IC. The capacitor at pin 18 must be small ($\approx 1 \mu\text{F}$) to avoid the possibility of internal damage to the IC by discharge current should pin 17 be short-circuited to ground.

Pin 19. Sandcastle pulse

The required three-level sandcastle pulse may be coupled directly to the sandcastle pulse detector input at pin 19. The horizontal blanking, vertical blanking and burst gate pulses are separated by the IC.

Pin 20. De-emphasis

De-emphasis is performed at this pin with a 1 k Ω resistor and a 470 pF capacitor. Additional filtering of the 8,8 MHz signal using an 82 pF coupling capacitor prevents moiré patterns appearing on the screen.

Pins 21 and 22. Clamping of (R-Y) and (B-Y) signals

Clamping of the colour difference signals is performed after they have been separated. The normal value for the clamping storage capacitors is 100 nF but this may be increased to 470 nF if required.

Pins 23 and 24. Demodulator reference tuned circuit

The SECAM signal is applied to the demodulator via a bell filter and a limiter amplifier. Only one chrominance demodulator is used because of the sequential nature of the signal. The reference signal from the tuned circuit is applied to pins 23 and 24. Tuning and damping adjustments of the reference tuned circuit should be performed at $V_{5.2} > 2 \text{ V}$ (SECAM video (R-Y) (B-Y) information switched off). Adjustments should be such that minimum modulator voltage appears at pin 8, then any deviations between the black levels (when clamping on the back porch and when an artificial black level is filled in) can be made minimum.

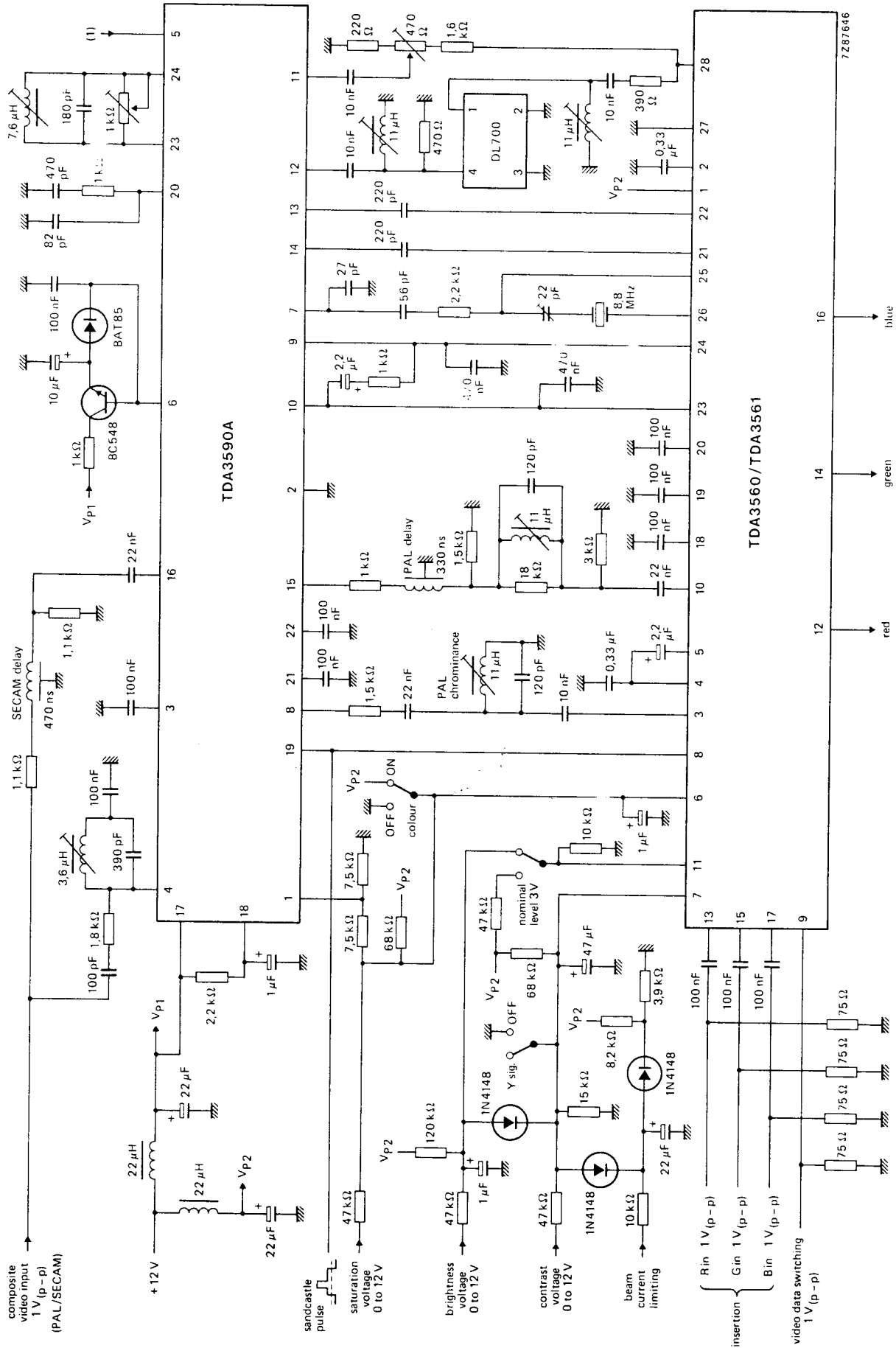

(1) See Application Information for pin 5 — horizontal/vertical identification.

Fig. 3 PAL/SECAM decoder application.

APPLICATION INFORMATION (continued)

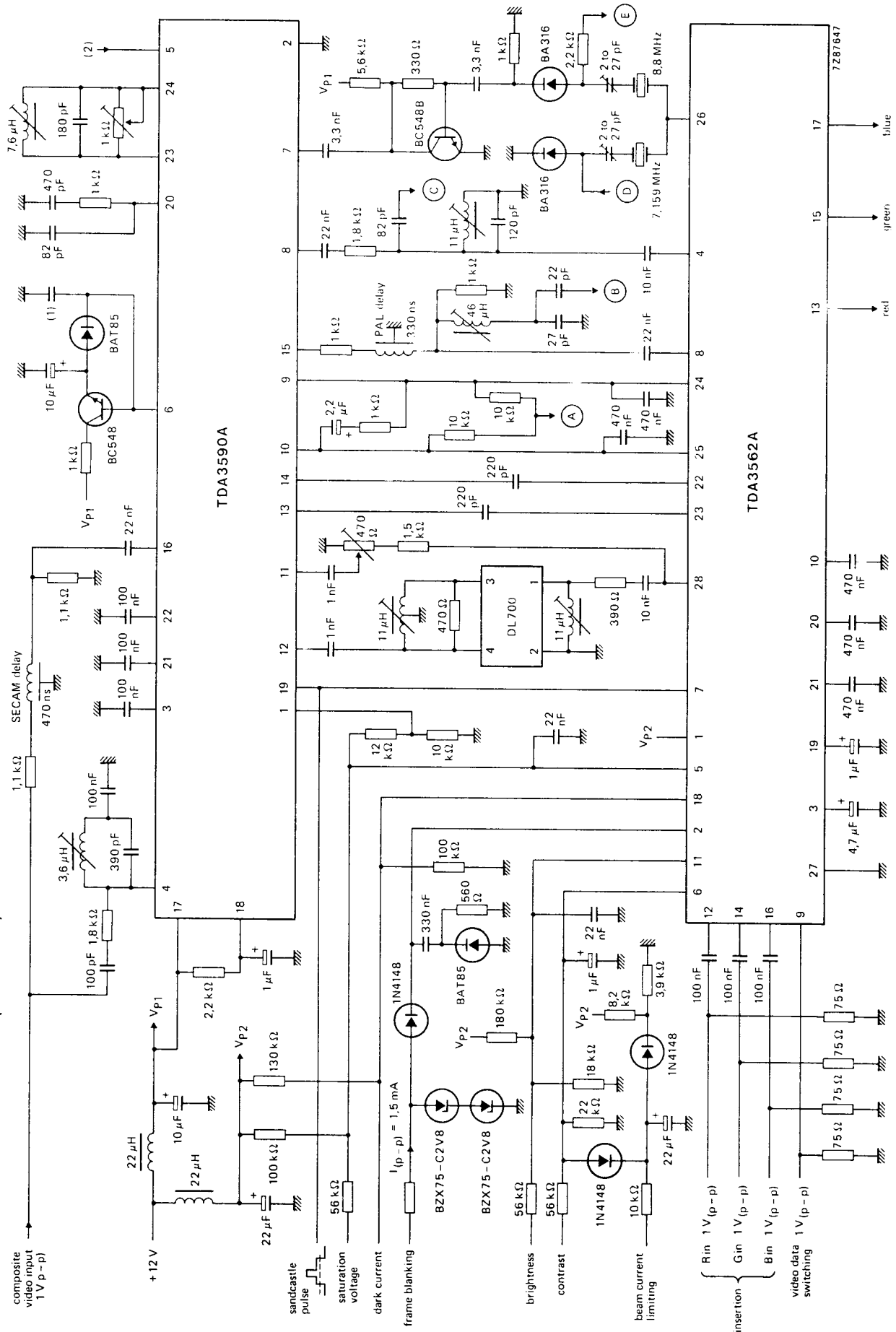
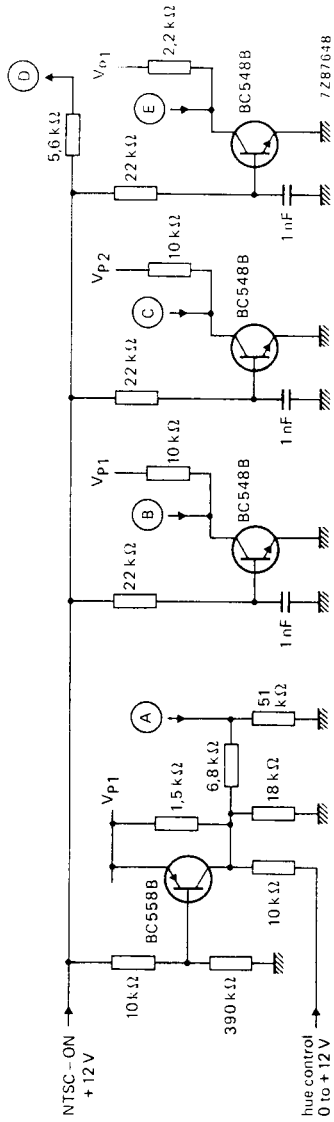

Fig. 4a PAL/SECAM/NTSC decoder application (continued in Fig. 4b).



- (1) Capacitor value = 100 nF for horizontal identification or 1 μF for vertical identification.
- (2) See Application Information for pin 5 – horizontal/vertical identification.

Fig. 4b PAL/SECAM/NTSC decoder application (continued from Fig. 4a).

This datasheet has been downloaded from:

www.DatasheetCatalog.com

Datasheets for electronic components.